

# MarinAire<sup>®</sup>

## Marine Air Conditioner Installation Manual

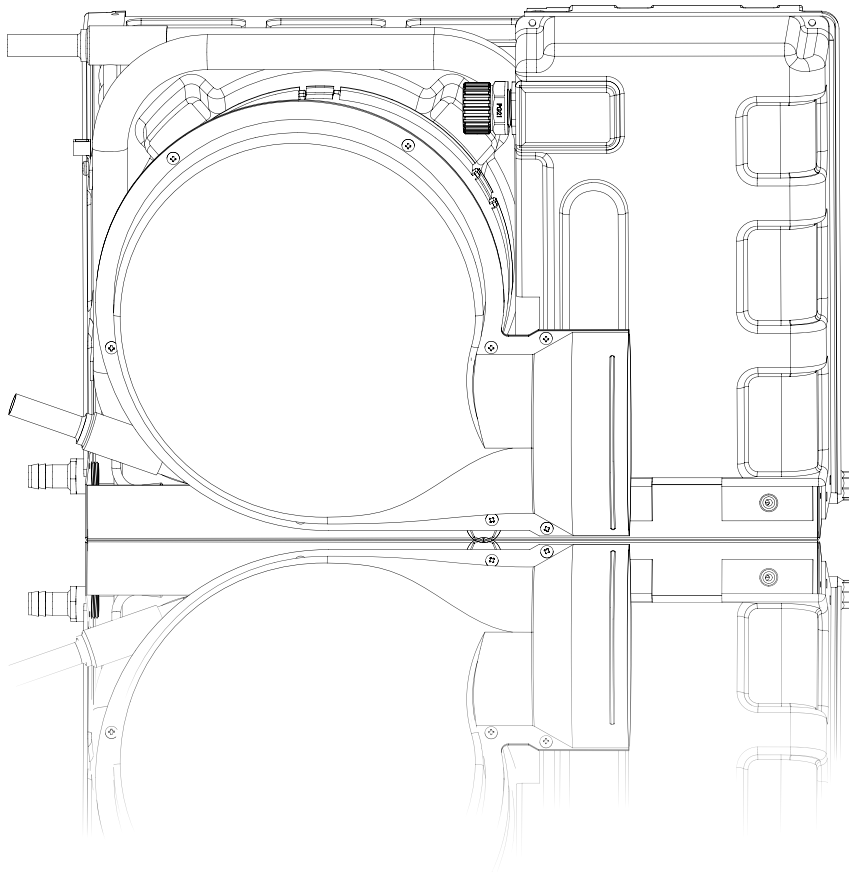

Applies to all MSWA models

- Please read this manual before use
- Keep this manual safe for future reference
- Installation and after sales services should be performed by marine AC mechanics



# TABLE OF CONTENTS

---

## A/C DESCRIPTION

Components ..... 1-4

A/C Features ..... 5

Cooling/heating Principle ..... 6

Circuit Diagram ..... 7-12

Dimensions ..... 13-17

## INSTALLATION

Installation Requirements ..... 18-19

Air Distribution ..... 20

Water Circulation ..... 21

Electrical Power ..... 22

Galvanic Corrosion Protection ..... 22

## GENERAL TROUBLESHOOTING ..... 23-27

## MAINTENANCE ..... 28

## MANUFACTURERS LIMITED WARRANTY AGREEMENT ..... 29-30

# A/C DESCRIPTION

## Components MSA6

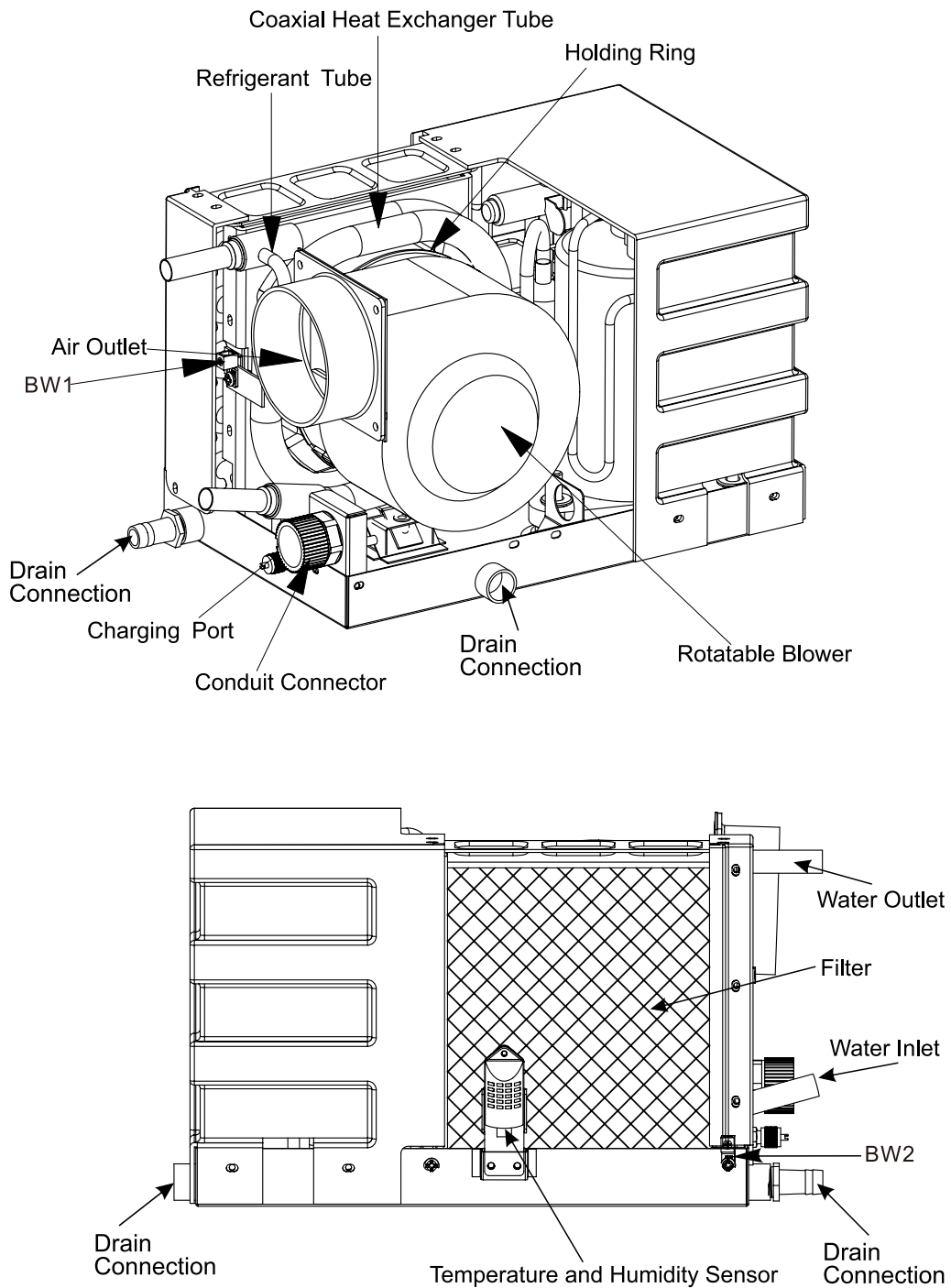

# A/C DESCRIPTION

## Components MSAW9

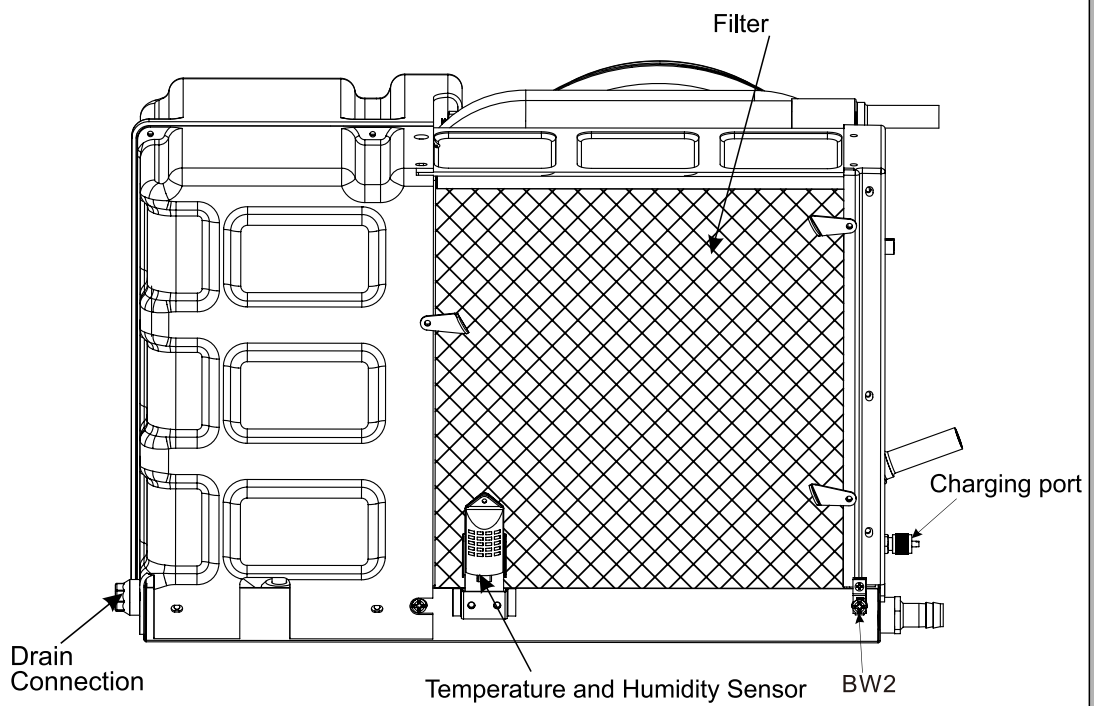
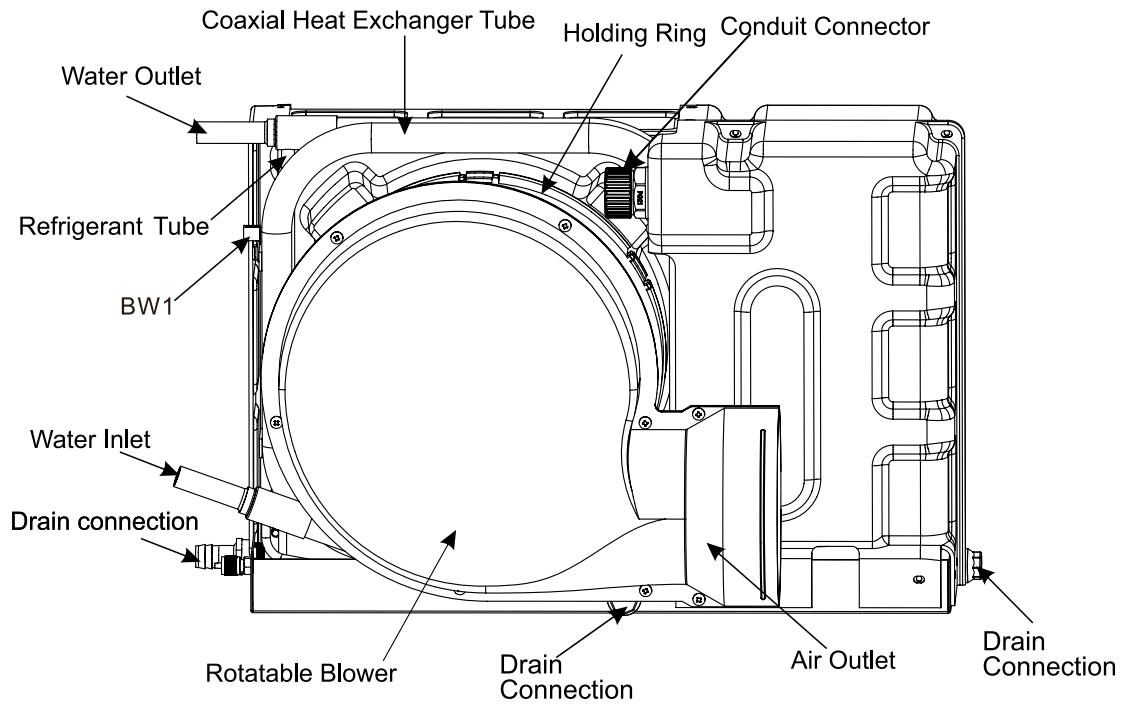

# A/C DESCRIPTION

## Components MSA11、MSWA14、MSWA16

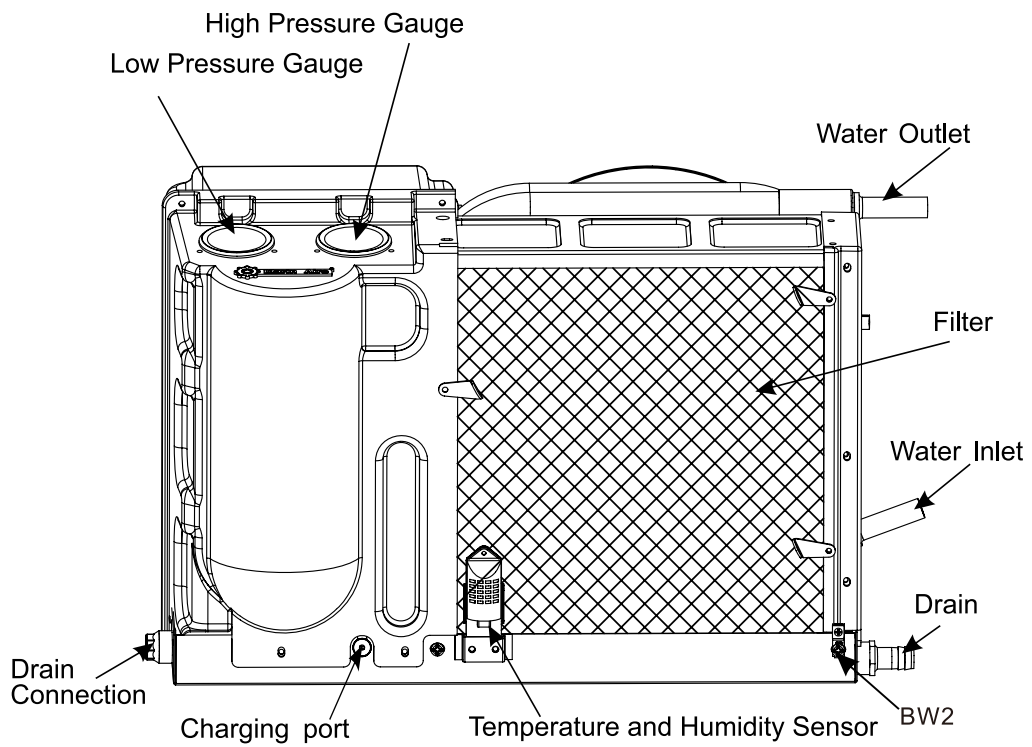
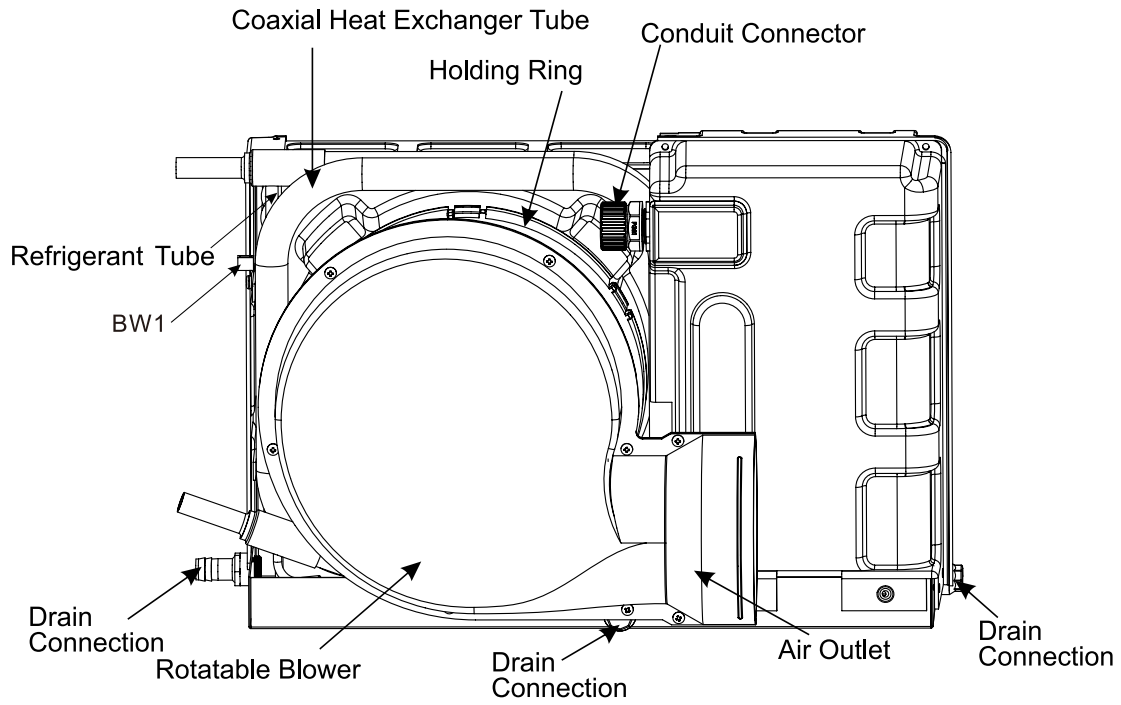

# A/C DESCRIPTION

## Components MSA20、MSWA24

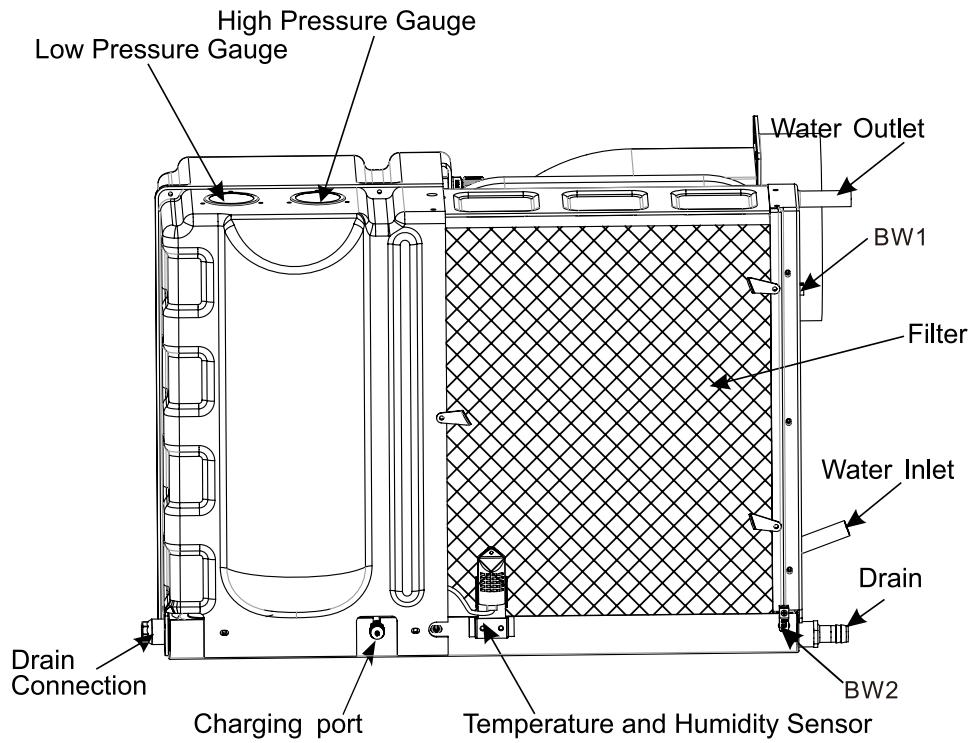
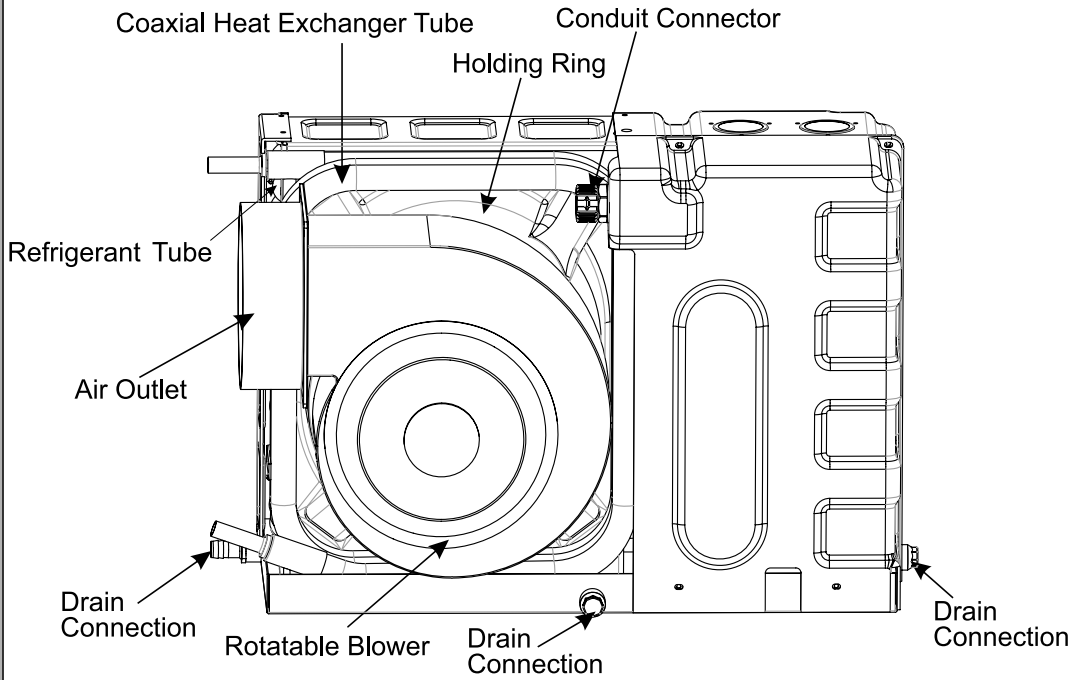

# A/C DESCRIPTION

## A/C Features

### MSWA9, MSWA11, MSWA14, MSWA16, MSWA20, MSWA24. 360 Degree Rotatable Blower

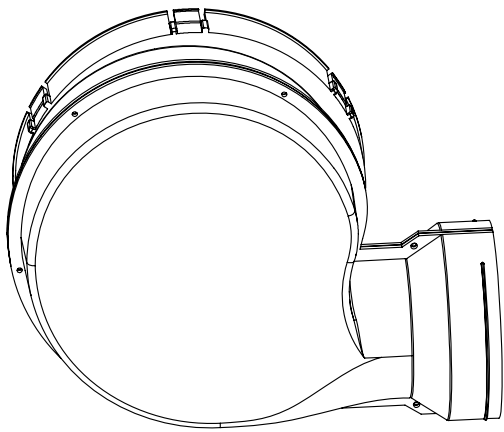

Fan

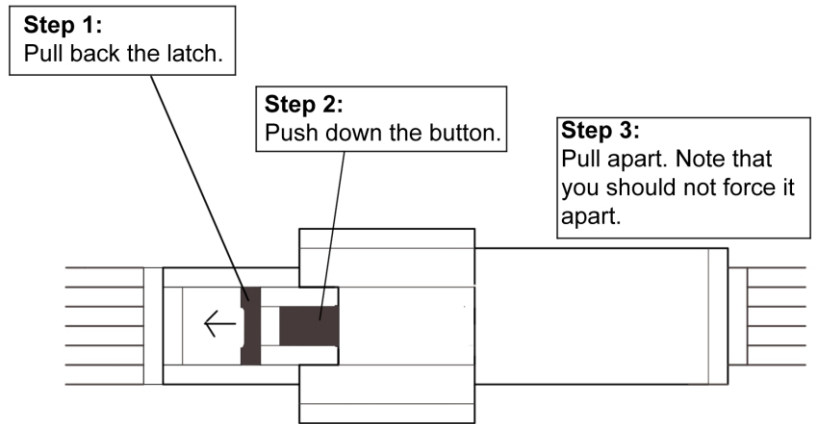

blower lock

※ 360-Degree Rotatable Blower.

The unique design makes it very easy to rotate the blower outlet. The blower can be rotated in any angle within minutes.

※ MSBA6 can be rotated up to a 90-degree angle.

(To change the blower angle, first loosen the metal clamp, then adjust it to the desired angle and re-tighten the metal clamp)

High, low pressure gauge and charging port

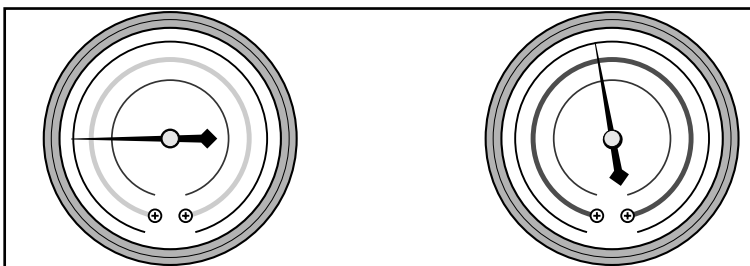

Low pressure gauge (Blue)

High pressure gauge (Red)

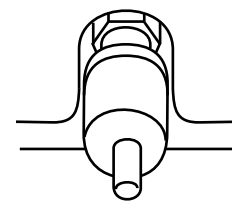

Charging Port

Entering Water Temperature	40	50	60	70	80	90	95	— °F
Low Pressure at Cooling operation	No operation	No operation	116	121.8	127.6	130.5	159.5	— PSI
High Pressure at Cooling operation	No operation	No operation	290	333.6	355.3	442.4	464.1	— PSI
Low Pressure at Heating operation	101.5	123.3	137.8	159.5	No operation	No operation	No operation	— PSI
High Pressure at Heating operation	391.6	435.1	493.1	551.1	No operation	No operation	No operation	— PSI



# A/C DESCRIPTION

## Principles of Refrigeration and Heating

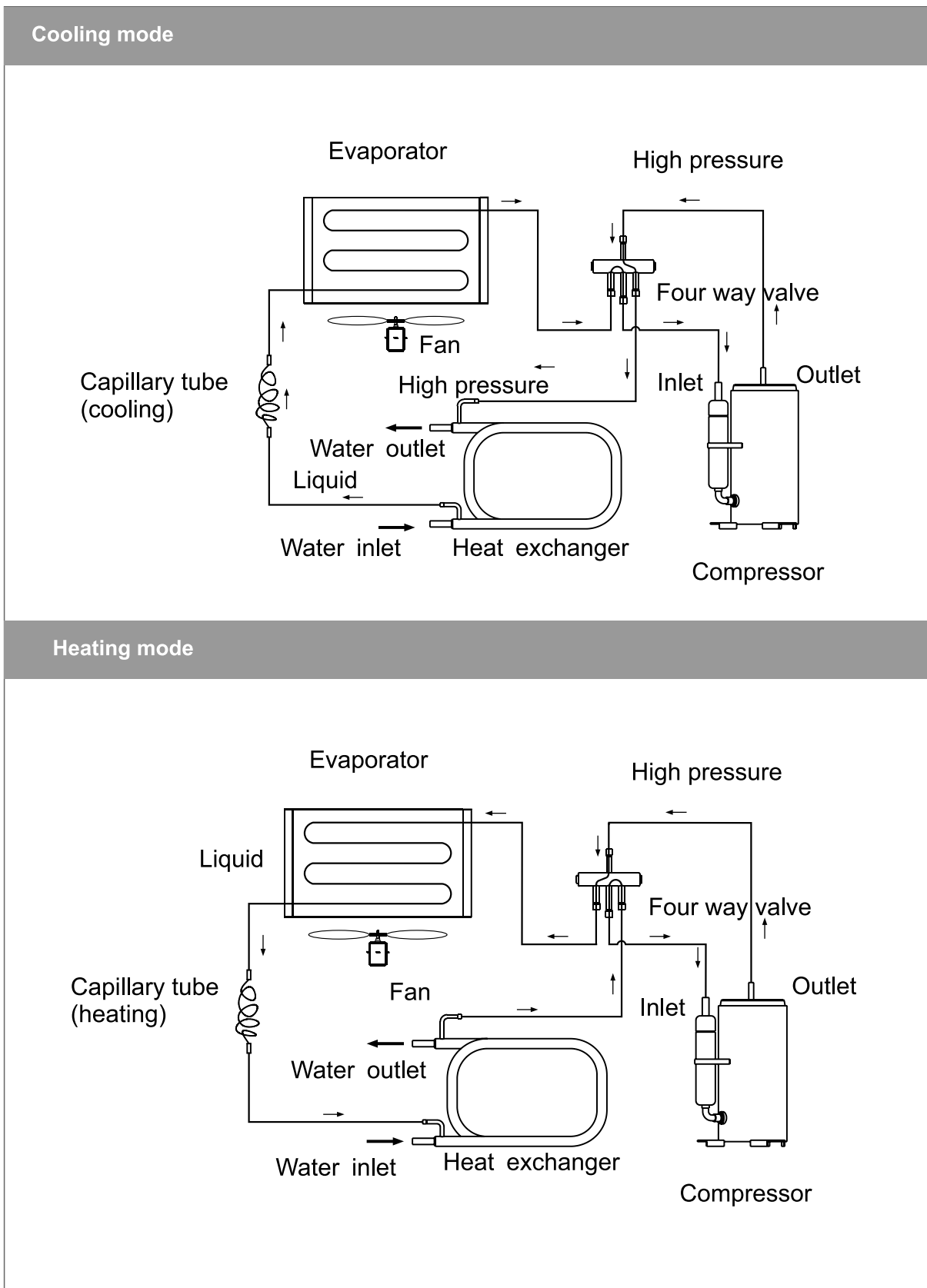

# WIRING DIAGRAM

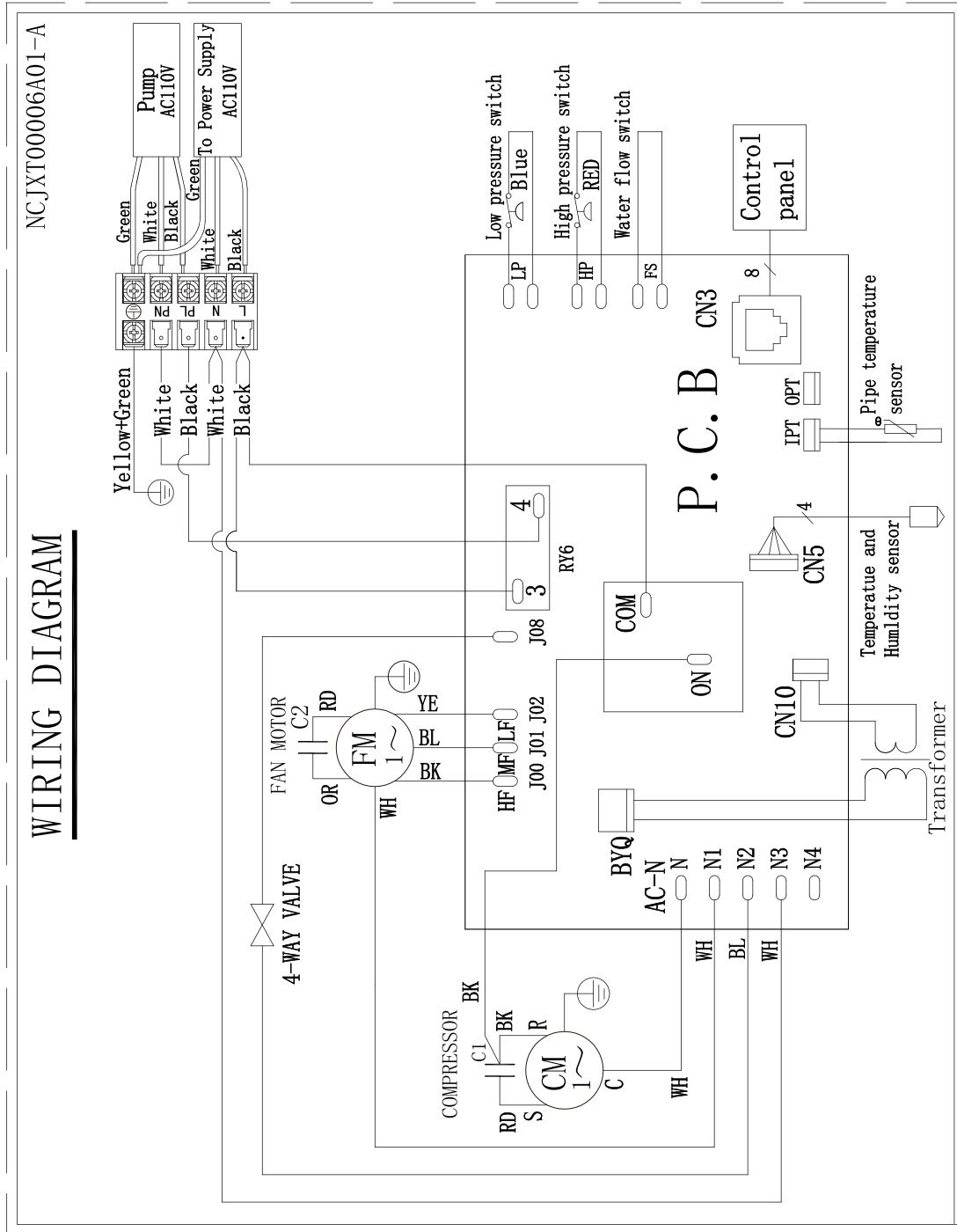

※ 110-120V/60Hz - MSAW6K2, MSAW11K2, MSAW16K2

# WIRING DIAGRAM

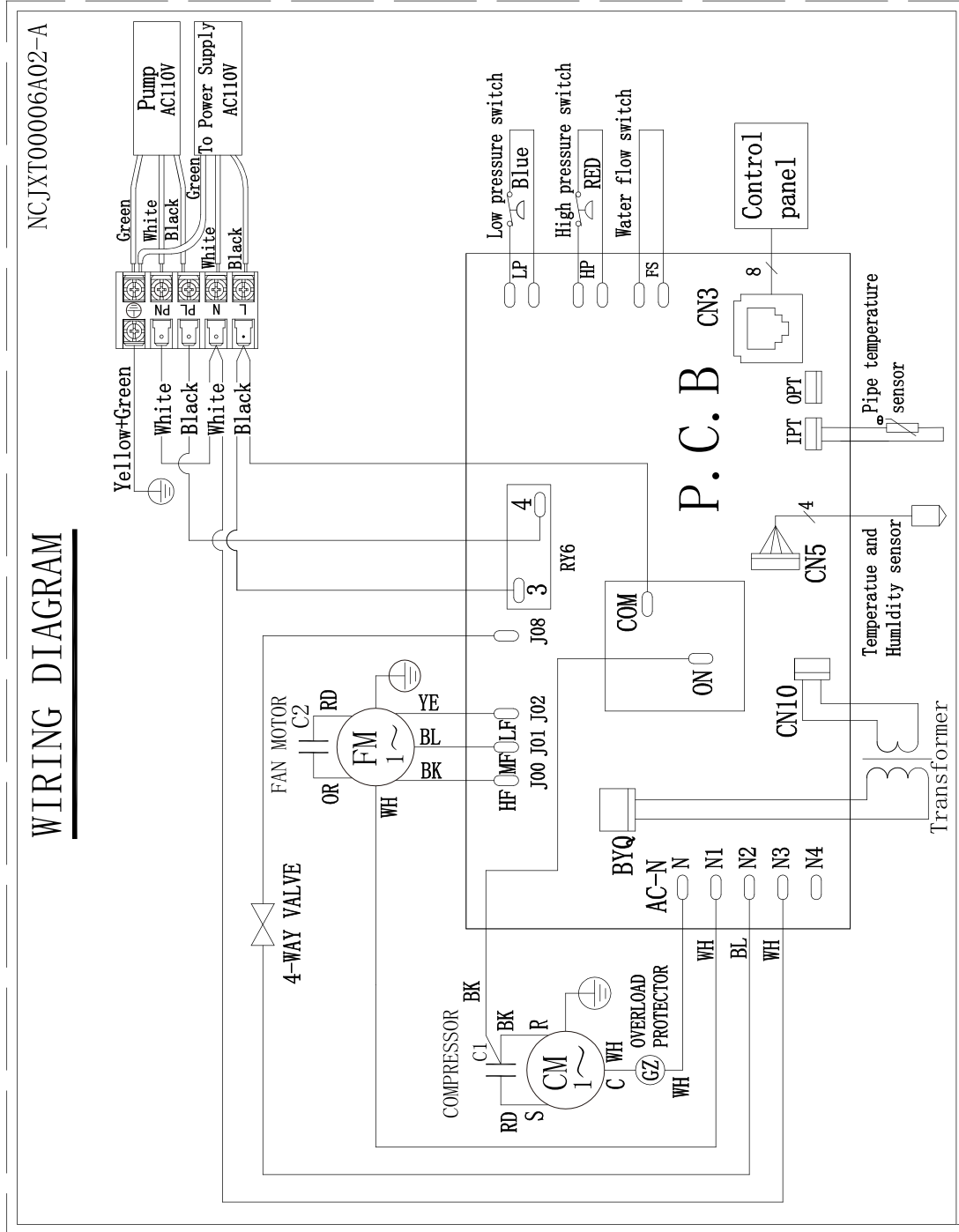

※ 110-120V/60Hz - MSAWA9K2,MSWA14K2

# WIRING DIAGRAM

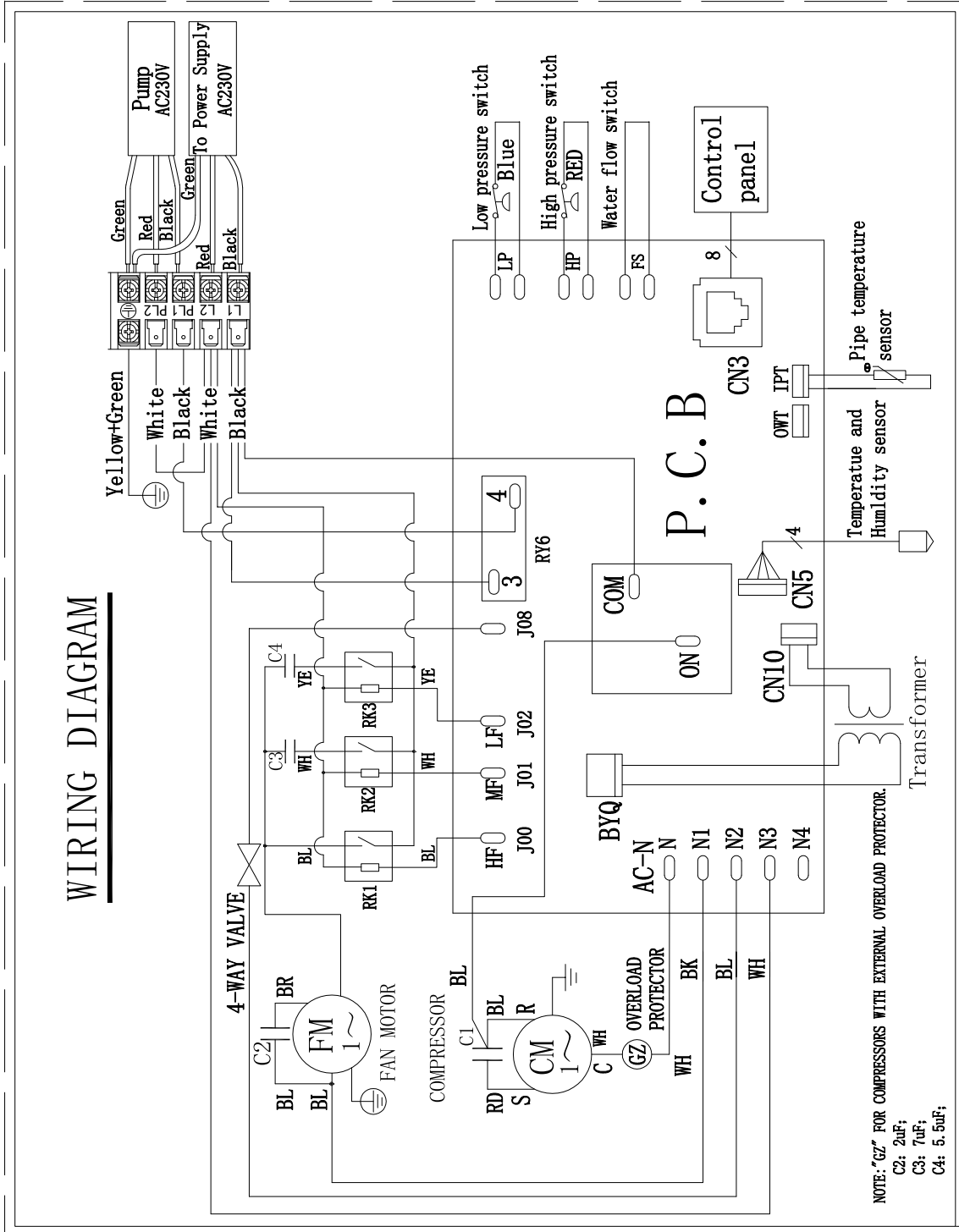

※ MSAW6C2

# WIRING DIAGRAM

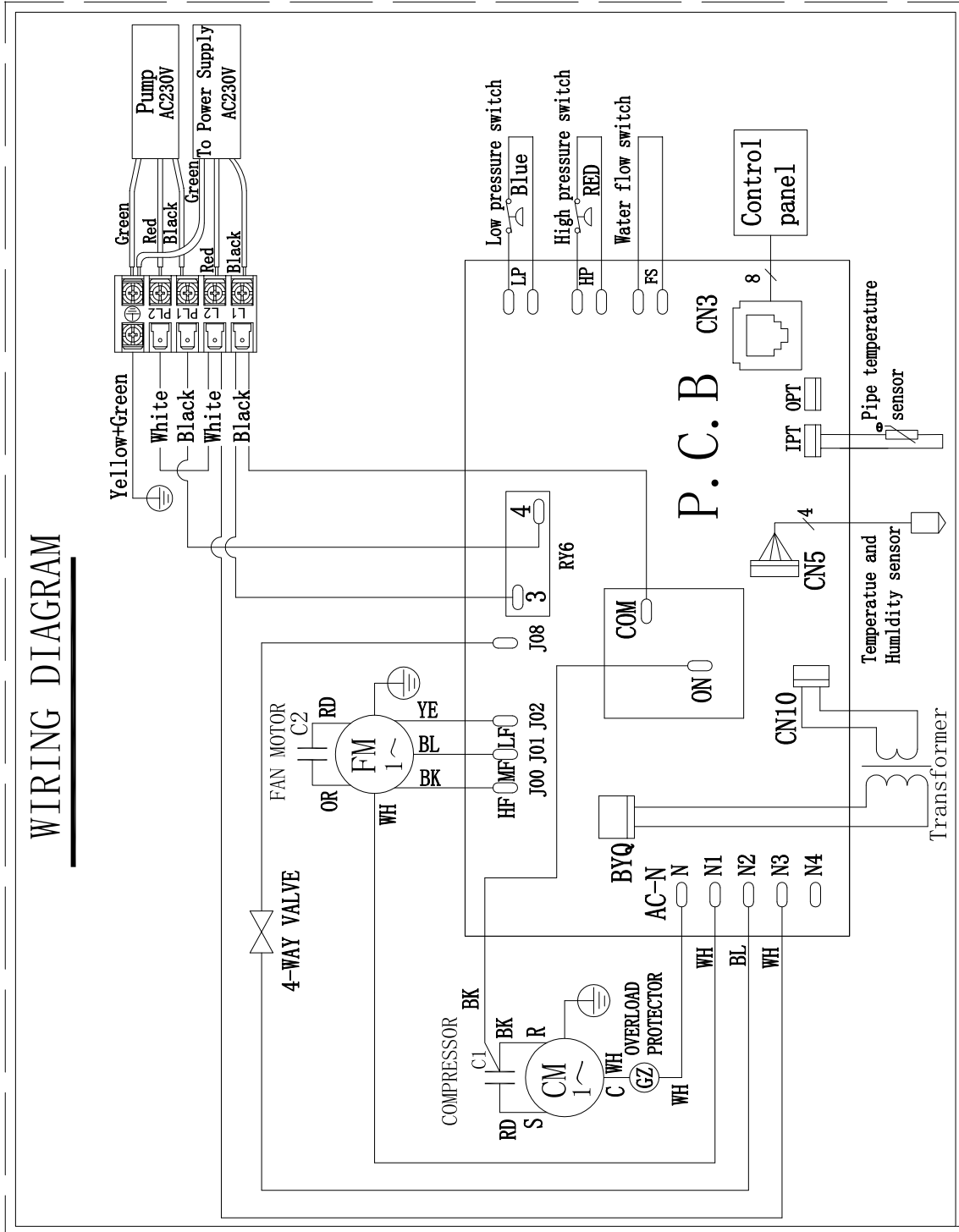

※ 230V/60HZ - MSA9C2, MSA11C2, MSA14C2

# WIRING DIAGRAM

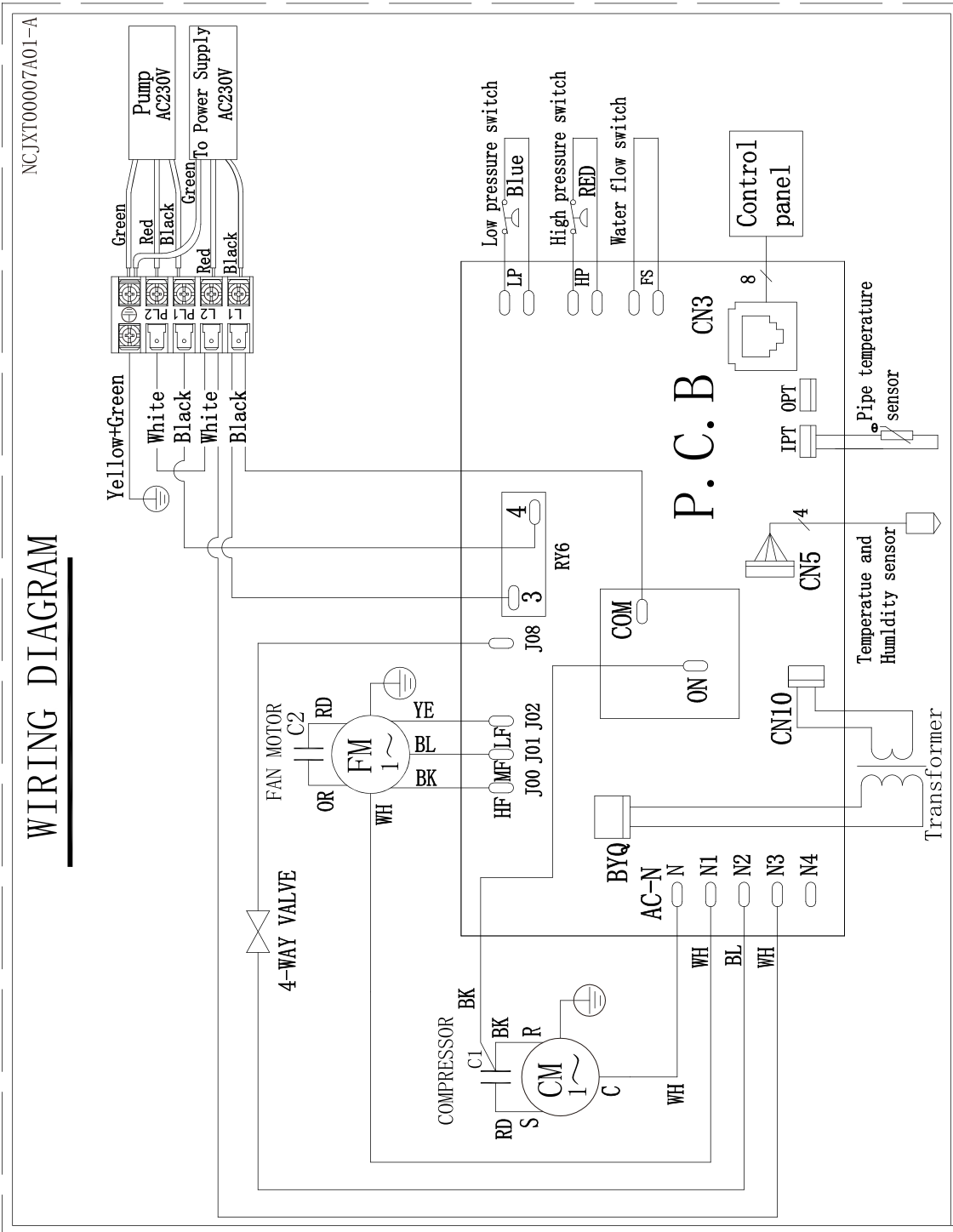

※ 230V/60Hz - MSA16C2

# WIRING DIAGRAM

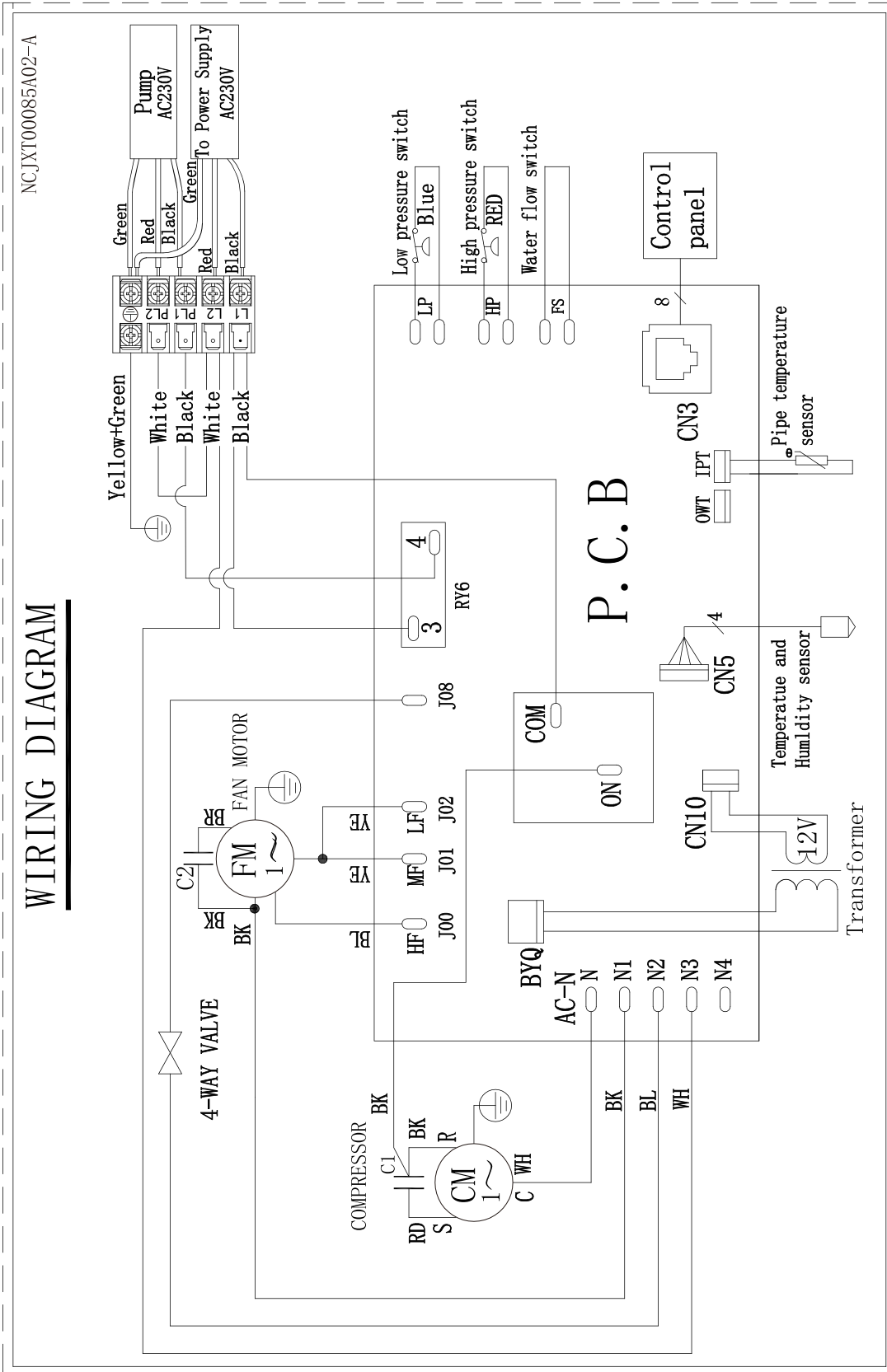

※MSWA20, MSWA24

# DIMENSIONS

## Dimensions

MSWA6K2

Dimensions	(in/mm)
A	17.5/445
B	9.5/242
C	10/251
D	11/280
E	4/101

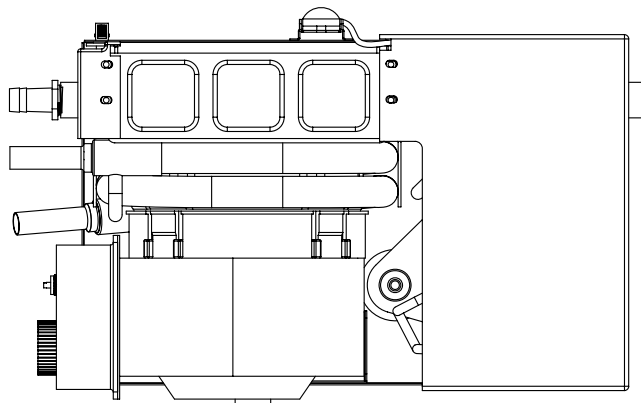
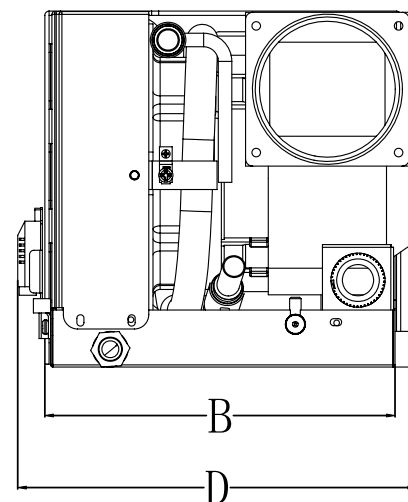
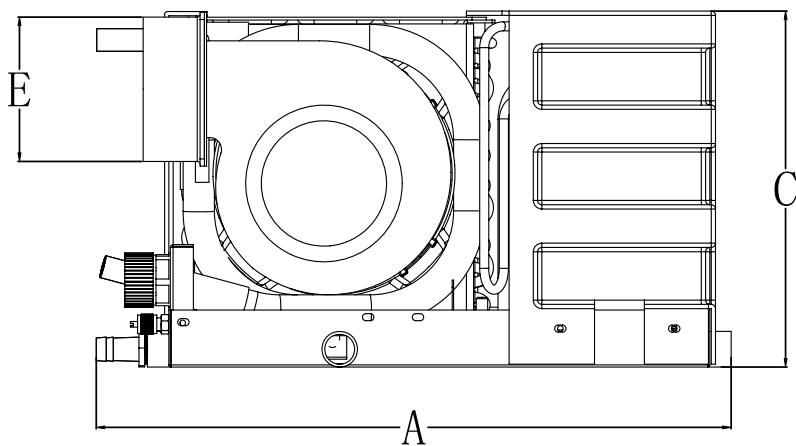



# DIMENSIONS

## Dimensions

MSWA6C2

Dimensions	(in/mm)
A	17.5/445
B	9.5/242
C	11.3/286.5
D	11/280
E	4/101

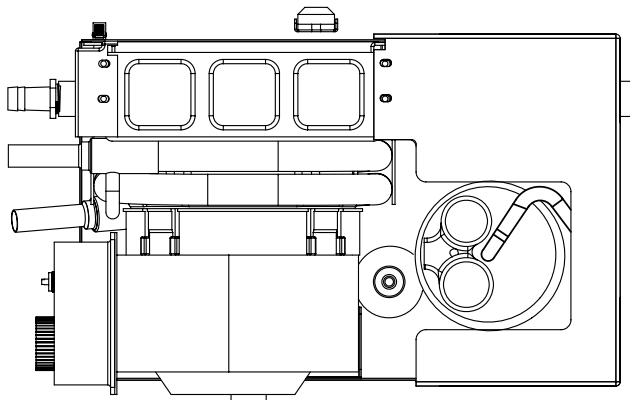
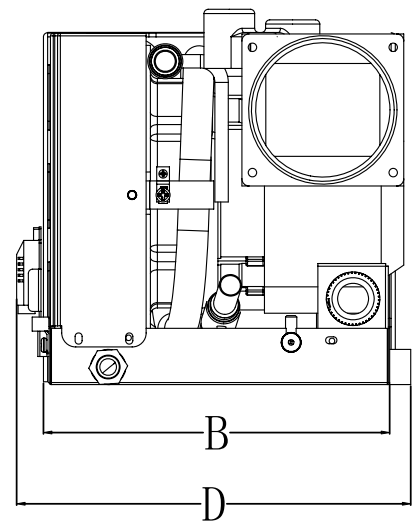
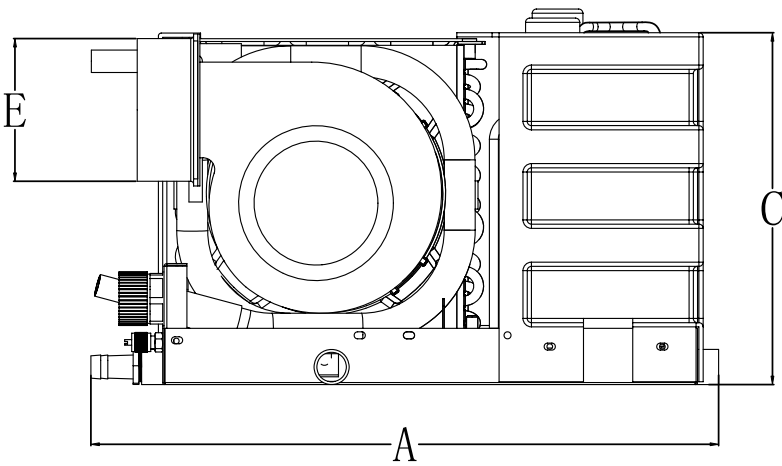

# DIMENSIONS

## Dimensions

MSWA9

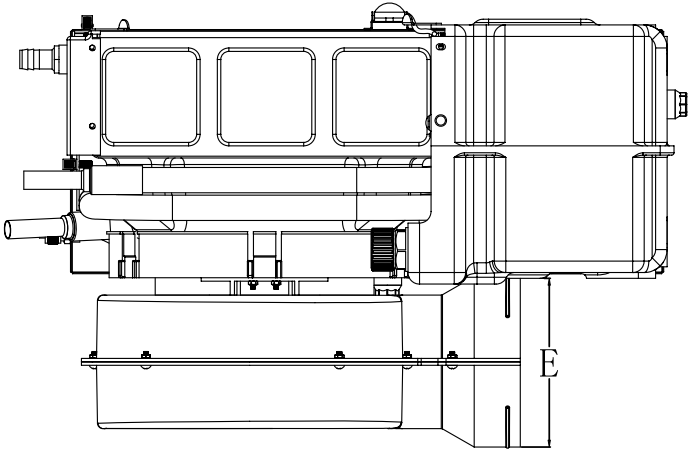
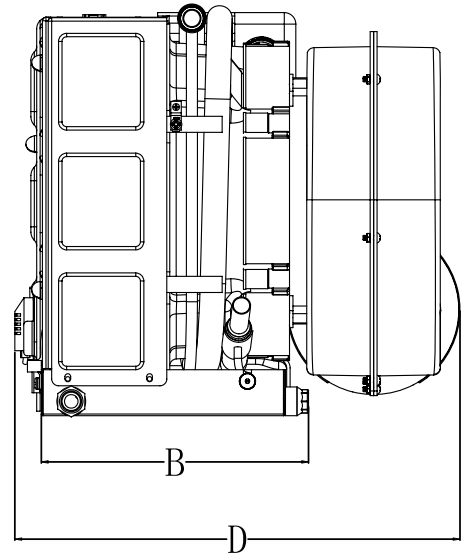
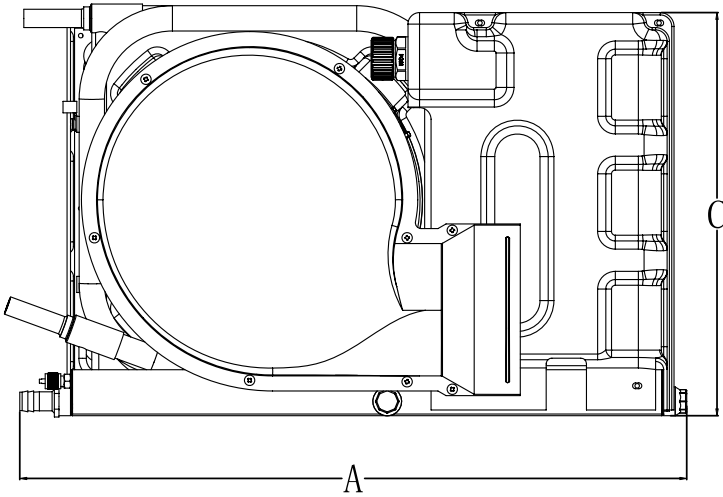

Dimensions	(in/mm)
A	22.8/579
B	9.1/232
C	13.8/350
D	15.4/390
E	6/152

# DIMENSIONS

## Dimensions

MSWA11, MSA14, MSA16

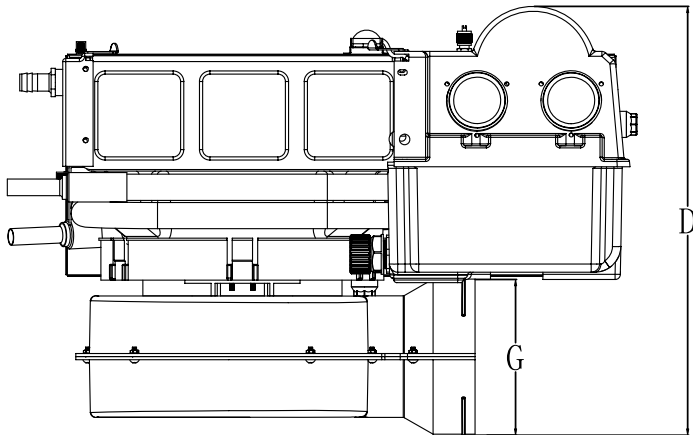
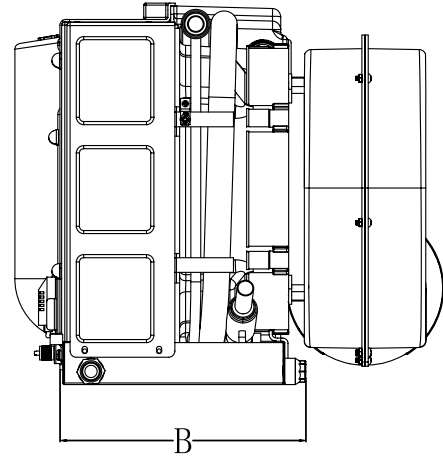
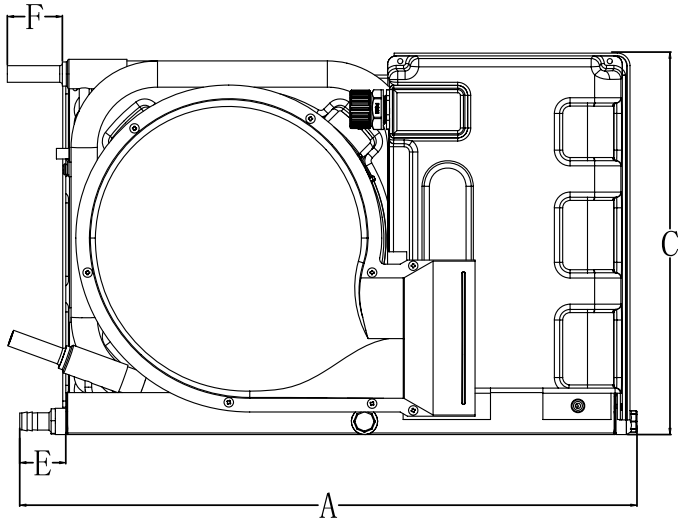

Dimensions	(in/mm)
A	23.2/590
B	9.3/235
C	14.4/365
D	16.6/422
E	1.7/44
F	1.9/50
G	6/152

# DIMENSIONS

## Dimensions

MSWA20, MSWA24

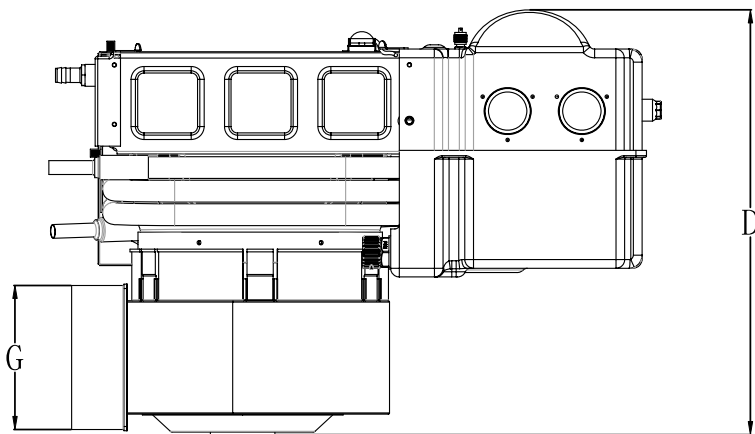
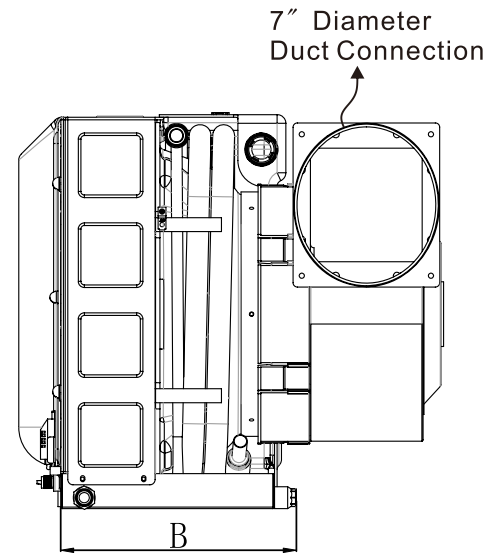
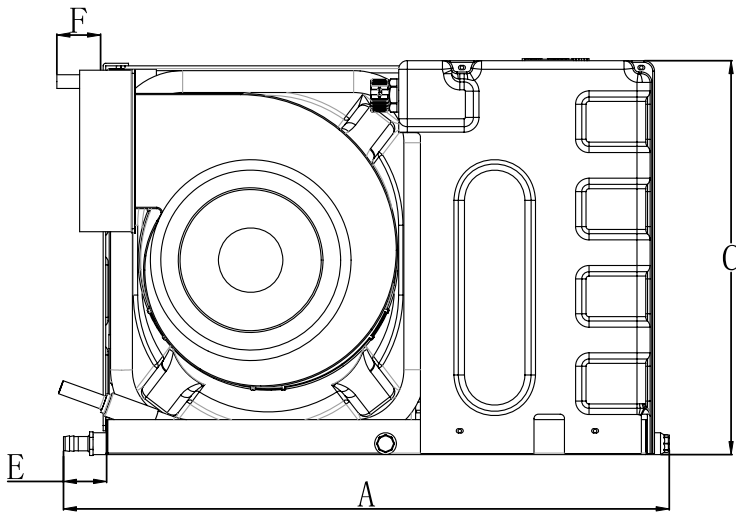

Dimensions	(in/mm)
A	27.3/694
B	10.6/270
C	17.6/451
D	19.2/487
E	1.95/49.5
F	1.9/50
G	6.5/165
	* 7" Duct Connection

# INSTALLATION

## Clean Air Act

MarinAire MSWA series use environmentally friendly refrigerant R410A. Refer to [www.epa.gov](http://www.epa.gov) for rules & regulations on how to handle R410A.

## Operation Limits

Cooling Operation: Incoming Water temperature (sea, river, lake water temperature) of 60 °F to 95 °F  
Heating Operation: Incoming Water temperature (sea, river, lake water temperature) of 40 °F to 77 °F

**Caution:** Operating your air conditioner & heat pump out of the above mentioned ranges might cause permanent damage to the compressor, heat exchangers, pump, and other plumbing components.

## Warning

The location of the AC must be sealed from bilge and/or engine room vapors. Do not install your air conditioner in the bilge or engine room areas. Condensate drain must not terminate overboard or close to any outlet of engine or generator exhaust systems. The air conditioner and the electric box must not be placed in an explosive environment or be exposed to an explosive environment or explosive materials, explosion could occur resulting in serious injury or death and/or destruction of the boat. This equipment does not meet requirements for ignition protection. Do not install in spaces containing gasoline engines, lpg/cpg cylinders, tanks, valves, regulators or fuel line fittings. Failure to comply may result in damages, serious injury, or death. Condensate drain should preferably terminate in a sealed condensate tank or shower sump pump, and must include a trap that will hold water when vessel heels or rocks.

Installation and servicing of this system can be hazardous. Similar to other air conditioning systems, this equipment involves electrical and high pressure components. Always disconnect power supply prior to performing installation, servicing or maintenance. To minimize the hazard of electrical shock and personal injury, this equipment must be grounded. All instructions labels and safety codes must be followed when working with this unit. When running, the compressor, and heat exchangers may be hot. Do not touch the equipment when running.

## Sizing

Make sure the selected capacity is not oversized for the applicable area. Over-sizing might cause damage to the electrical components and/or to the power supply due to frequent starting and stopping. Over-sized air conditioning will not effectively remove the humidity and may cause high humidity and encourage mold in the cabin. This may also cause high energy consumption. Slightly under-sizing may be applicable, but significantly under-sizing your air conditioning will cause discomfort when you need it the most. The general rule of thumb for sizing a pleasure boat is 14BTU's/cubic foot. Use the formula of 16 to 19 BTU's/cubic foot for areas that are used during the heat of the day that have a lot of sunlight coming in, such as a pilothouse, especially if the roof is not shaded or well insulated. For areas below deck that are primarily used after sunset such as a stateroom, you can use the formula of 10 - 12 BTU's/cubic foot. Please consult with a professional for the most accurate sizing recommendations.

# INSTALLATION

## Location of the system

Typical spots are under the V-berth, in hanging lockers, under dinette seats, in cabinets or in outside dry lazarettes and the bottom of lockers. The equipment and peripheral components must fit in and/or be accessible in the selected location. The unit should be positioned on a firm, level, and horizontal (flat) surface and the condensate drain line should run in a downward slope from the unit to a suitable drain location. The drain works with gravity. If you can not find a location for the size of the air conditioner base plate, a mounting shelf or platform must be built. Typically the shelf may be made from 3/4 inch marine grade plywood, which can be either fiber-glassed or mechanically attached to the boat's sole or superstructure. Do not screw directly into the hull. Never place the electrical box below the air conditioning unit. It is strongly recommended that you locate the return grille as low as possible and the supply air grilles as high as possible in the cabin. This will provide better air circulation. Carefully plan all connections including ducting, splitter, grilles, condensate drain, water in and out, water filter, water circulation pump, electrical power connections and location of the wall control unit,

## Mounting legs & Vibration Absorbers

The AC unit is supplied with a base pan that also serves as a condensate pan. Mounting legs and vibration absorbers are provided to secure the base pan onto a flat surface.

# AIR DISTRIBUTION

## Blower Assembly

The blower can be easily rotated 360° for an optimal angle, or removed for servicing (90 degrees for the MSWA6). Simply loosen the metal clamp and rotate the blower outlet to the desired angle and tighten the metal clamp again. Do not leave the clamp loose and do not over-tighten it, as it may apply excess tension to the shroud and cause the plastic to crack.

## Ducting

Install at least one vent within 4 to 5 feet of the unit. Make sure that the airflow is not directed back towards the return air grill. Guidelines below should be followed as a rule of thumb;

6,000 btu unit: 2 or 3 pieces of 4" ducts and supply grills.

9,000-11,000 btu unit: 3 or 4 pieces of 4" ducts and supply grills

14,000 btu unit: 3 or more pieces of 4" supply grills or one 6" supply grill and 2 or more 4" supply grills

16,000 btu unit: One 6" supply grill and 2 or more pieces of 4" supply grills

20,000-24,000 btu unit: 3 or more pieces of 6" supply grills

An air splitter is required if more than one supply air grill is used. Splitters may be mounted directly on the unit output, or placed in line a short distance from the unit in case of space restrictions. Use insulated duct if the ducting passes through hot and humid areas. If the ducting is completely inside the air conditioned area, you may use non-insulated duct. Using non insulated duct may cause water condensation.

Generally, it is recommended that insulated ducts are used to eliminate condensation. Sail boats generally sit lower in the water and have less glass than power boats, they tend to produce more duct condensation than power boats. All duct runs should be as short and straight as possible. Each 90° bend can reduce airflow by 15% to 20%. Ducting should be properly tied to a permanent structure to eliminate sagging.

Four inch round grilles require a 4.5 inch diameter hole. A wood or plastic rectangular grille requires a rectangular cut-out of the same nominal size as the grille. A transition box is required behind the grill on the other side of the partition or bulkhead and will be approx. 4" deep.. Transition boxes are required in order to be able to connect the duct to the grille.

## Return Air

6000 btuh to 9000 btuh needs 80-100 square inches (8X10" to 10X10")

11000 btuh to 16000 btuh needs 120-150 square inches (10X12" to 10X15")

20000 btuh to 24000 btuh needs 200 square inches or bigger

Always use return grilles with a filter. Make sure that the air returning to the AC unit is properly filtered.

Ensure that there is no air returning to the unit from elsewhere. Unfiltered air with dust, dirt and debris will cause poor performance and potential malfunction. Do not place any object to obstruct the return air grille. For the best performance, the evaporator side of the unit should face the return air grille. The evaporator should be at least 3" away from the wall if installed sideways.

Where it is not possible to have a single return grill multiple grills may be used. Do not stow items such as life preservers, bedding or other items of this nature between the evaporator and the return air grill.

## Condensate Drain Connection

During cooling or dehumidifying mode operations, the air conditioner may produce up to 1 gallon of condensate water per hour. It is important that condensate drains run downward in a continual slope, with no rises where the air can form a pneumatic lock. There must be a trap that will hold water if the vessel heels or rocks. Terminate drain in a dedicated sump. Although it is not recommended, you can terminate drain in the bilge if there is a properly working bilge pump installed (Severe damage and flooding can occur if the bilge pump fails). The drain can also be connected to a condensate pump. Test the installation by pouring water into the drain pan and checking for good drainage.

## Water in & out

Cooling water must be supplied via a dedicated scoop-type thru-hull facing forwards, a ball valve, and a pump, all of which are mounted as low as possible below the waterline. Use 5/8 inch ID marine grade water hose. Water from the pump enters the condenser (water coil) on the lower fitting and exits through the higher one. In case water connection is not straight, it is recommended to use a hose barb 90 degree fitting to eliminate any kinking. Take care to ensure that the water hoses will not become kinked or restricted in any way. Install a sea water strainer between the ball valve and the pump. The seawater strainer must be installed below the level of the pump and should have good access for cleaning. Connect the discharge from the unit to a fitting which is located just above the sea level. Double clamp all hose connections with stainless steel clamps, reversing the clamps. Use Teflon tape on all threaded connections. Refer to below illustration for details.

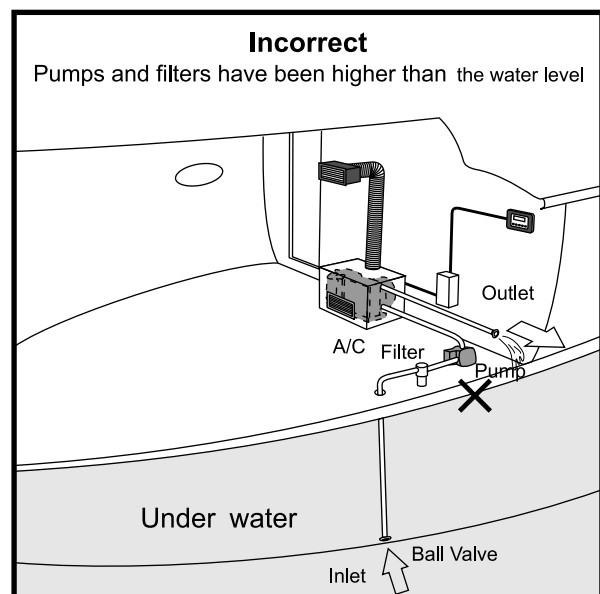
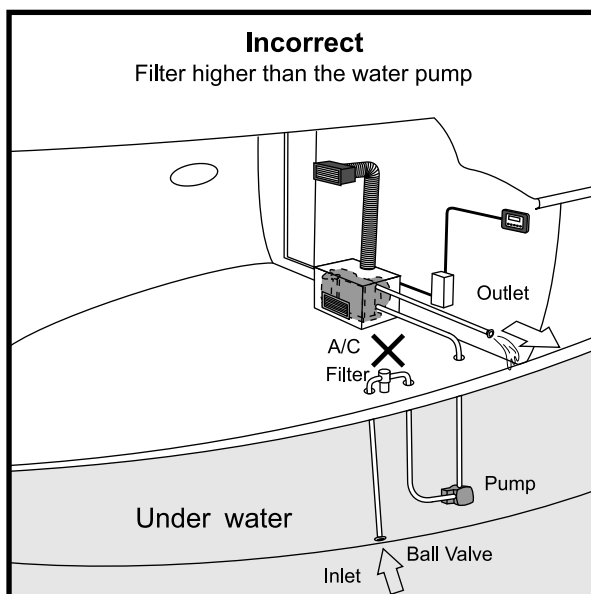
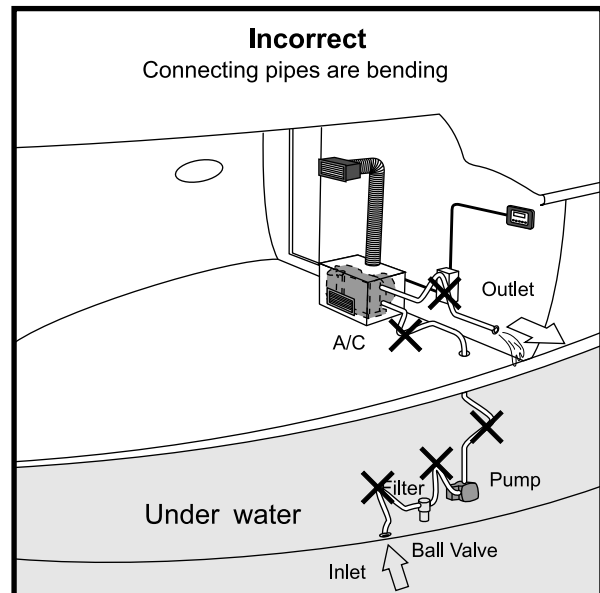
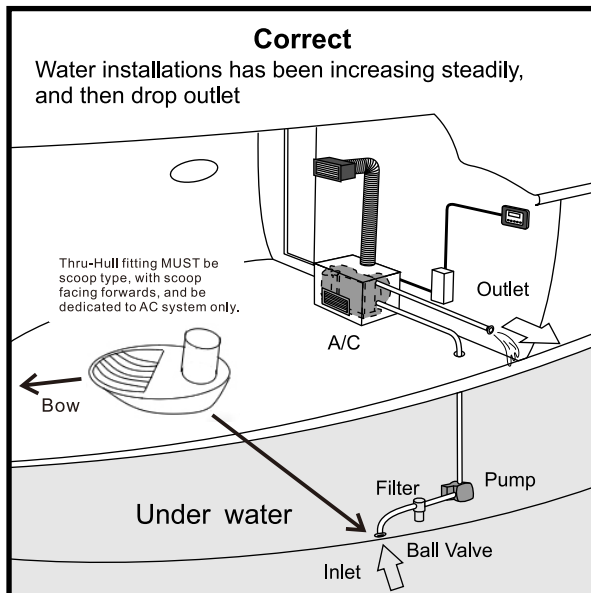



# INSTALLATION

## Electrical Power

Both the air conditioner and pump should require the same voltage. Make sure the power source is correct for the equipment. ( 110-120V/60Hz, 208-230V/50-60Hz and 220-240V/50Hz models available) Power is obtained from the master Circuit Breaker Panel in the boat. Power cables run from this panel to the air conditioner. The air conditioner will then supply power to the pump as required. A terminal strip is mounted inside the Electrical box. The terminal strip is labeled for proper connections of the electrical supply, ground wires and pump circuits. A wiring diagram is provided in the electrical box. Minimum of 12 AWG boat cable should be used to supply power to the a/c unit and the seawater pump. Proper grounding is mandatory. A ground connection is provided in the electrical box. All connections shall be made with ring or captive fork terminals. Pump should be connected directly to the terminal strip in the electrical box unless a pump relay panel is used. Turn off the AC power supply circuit breaker before opening electric box. The AC unit must be connected to the ship's bonding system to prevent corrosion due to stray electrical current or voltage. All pumps, metallic valves and fittings in the seawater circuit that are isolated from the AC unit by PVC or rubber hoses must be individually bonded to the vessels bonding system too.

Use a 20 amp breaker for the MSA14K2, MSA16K2, MSA20C2, MSA24C2.

Use a 15 amp breaker for all other models.

## Galvanic Corrosion Protection **IMPORTANT: PLEASE READ**

Electrolysis may occur any time an air conditioner is connected to a shore power that is shared by other boats in a marina. Electric current passes through water between neighboring boats. This is when the general corrosion problems start. It will first attack the weaker or less noble metals such as zinc and aluminum until they disappear. Therefore, Cathodic protection is extremely important so that the sacrificial metals (zinc and/or aluminum) will be corroded instead of the air conditioner.

Cathodic protection is the practice of connecting an air conditioner to an external sacrificial anode(s) that is usually a zinc plate or an aluminum plate mounted outside the hull. Make sure all connections are good quality. If you have a bonding circuit, tie it into the cathodic circuit for extra protection. **There are two bonding points on the air conditioners. One at the coaxial coil (BW1) ( upper installation leg) and one at the drain pan (BW2). Both points needed to be connected to the sacrificial metal plate.**

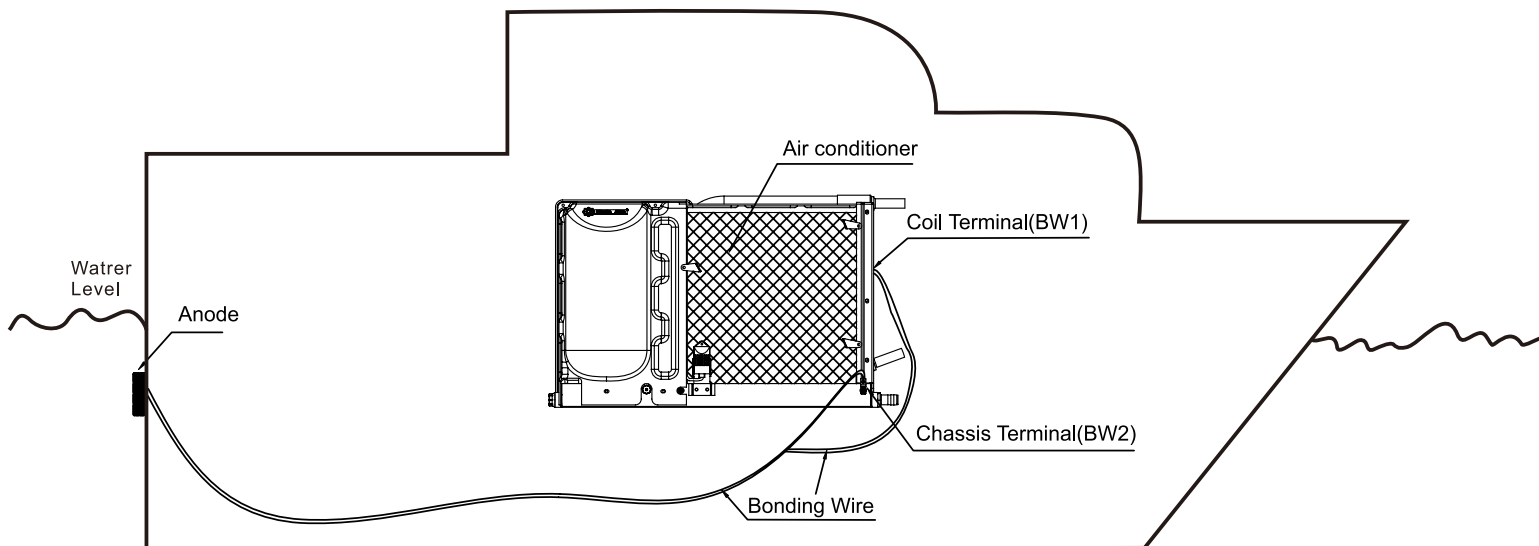

# MALFUNCTIONS INSTRUCTION (MSWA Series)

## 1 Humidity sensor error

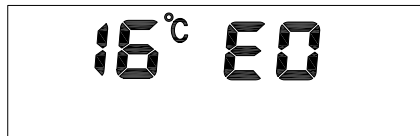

If your device displays E0, it means that the communication between the humidity sensor and the main circuit board is having problems. This may be because the humidity sensor cable on the circuit board is loose, or the cable between the sensor and the circuit board is broken. Please try to unplug the white socket with four pins, and plug it in again. The humidity sensor may also get defective if water spills over the sensor or if there is physical damage to the sensor. In case the sensor or cable is defective, then the solution is to replace the sensor or its cable. Please note that the MSWA units are equipped with dual sensors. The humidity and the return air sensor are combined in the small gray plastic casing located at the left bottom corner of the air filter.

## 2 Freeze Protection

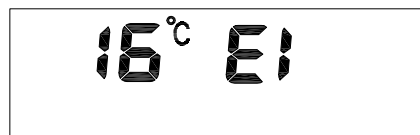

If your device displays E1, it means that the evaporator coil is getting too cold. MSWA units have a temperature sensor located on one of the evaporators copper tube. Once the evaporator coils temperature gets below 30 °F ( -1 °C ), then the compressor will be turned off to prevent the coil from freezing. The unit will then display E1. This may happen on air conditioning mode or on dehumidifying mode and if the air flow is insufficient. Please check and make sure that you have the appropriate size of ducting based on the capacity of your unit, all the vents & diffusers are fully open, the return grill size is appropriate, filters are clean, and that there is no obstruction to the air flow. Improving the air flow will automatically resolve this sue.

## 3 Indoor temperature sensor Error

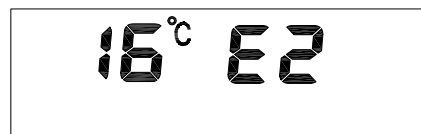

If your device displays E2, it means that the communication between the return air temperature sensor and the main circuit board is having problems. This maybe because the return air temperature sensor cable on the circuit board is loose, or the cable between the sensor and the circuit board is broken. Please try to unplug the white socket with four pins, and plug it in again. The temperature sensor may also get defective if water spills over the sensor, or if there is physical damage to the sensor. In case the sensor or cable is defective, then the solution is to replace the sensor or its cable. Please note that the MSWA units are equipped with dual sensors. The humidity and the return air sensor are combined in the small gray plastic casing located at the left bottom corner of the air filter.

# MALFUNCTIONS INSTRUCTION (MSWA Series)

## 4 Coil temperature sensor Error

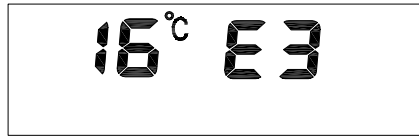

If your device displays E3, it means that the communication between the return evaporator temperature sensor and the main circuit board is having some problems. This may be because the small socket on the circuit board is loose or the cable between the sensor and the circuit board is broken. Please try to unplug the blue socket with two pins, and plug in again. In case the sensor or cable is defective, then the solution is to replace the sensor cable. Please note that the evaporator coil temperature sensor located on the top copper tube of the coil. In order to access to the tip of the sensor, you will need to remove the screws at the bottom of the compressor sound shield and pull the plastic parts apart from each other.

## 5 High Pressure protection

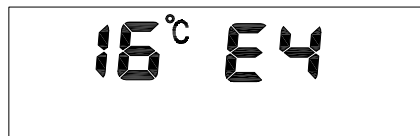

E4 is the code for high pressure protection. If your device displays E4, it means that the pressures are higher than normal levels. Once the high side is above 550psi, the compressor will be turned off and the unit will display E4. Once the pressure gets normal again, the controller will automatically reset itself and the unit will work again. The controller will automatically reset only twice. If it happens for the third time, then it will not reset automatically. In this case you will need to find the cause that leads to the high pressure and fix it before you can reset the controller. Once you fix the problem, you will need to turn the power off for ten seconds and turn it on again to reset the memory. The pressures may be raised during the air conditioning mode, dehumidifying mode and heating mode.

### HEATING MODE

Please note that the pressures may get high if the water inlet temperature is high and above 70 °F (21°C). With the combination of the warm waters, insufficient airflow and high setting temperature, the pressures may go above the limit even if the water temperature is below 70 °F, then the pressures will rise and then the high pressure switch will cut the operation to protect the unit. If the airflow is insufficient on heating mode, the heat will not be removed sufficiently from the coil. Please check and make sure that you have appropriate size of ducting based on the capacity of your unit, all the vents & diffusers are fully open, the return grill size is appropriate, filters are clean and there is no obstruction to the air flow. Improving the air flow may automatically resolve the issue.

### COOLING & DEHUMIDIFYING MODE

During cooling mode or dehumidifying mode, water flow is very important. If the water flow is insufficient, then the pressures will rise and then the high pressure switch will cut the operation to protect the unit. Please check the water flow. Make sure that the pump is working, the water lines as well as the strainer are clean and free from any obstruction. You can measure the water flow using a 5 gallon container and time it. Below are the approximate values that you should measure from the overboard.

60 00 btu : 2 gallons per minute ( a 5 gallon container should be filled with 120 seconds )

90 00 btu : 3 gallons per minute ( a 5 gallon container should be filled with 100 seconds )

11000 btu : 4 gallons per minute ( a 5 gallon container should be filled with 75 seconds )

140 00 btu : 4.6 gallons per minute ( a 5 gallon container should be filled with 65 seconds )

160 00 btu : 5.5 gallons per minute ( a 5 gallon container should be filled with 55 seconds )

# MALFUNCTIONS INSTRUCTION (MSWA Series)

## 6 Low Pressure protection

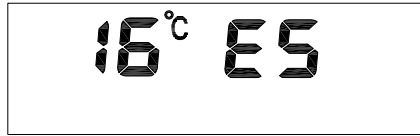

E5 means that the pressure levels are lower than normal. Please check the gauges. Once the compressor is not running, both the low and the high pressure gauges should show about 200 ~ 220 psi level (depending on the ambient temperature, the idle pressure may be a little lower or higher)

If the unit displays E5 almost immediately after the startup, it means that the unit has lost its refrigerant because of a leak. In this case, a technician should check the unit and find the location of the leak, fix the leak and pull vacuum then recharge the system.

If the unit runs about 10 minutes and longer before it displays E5 during the heating mode, then it may be because of insufficient water flow.

If the unit runs for about 10 minutes and longer before it displays E5 during the air conditioning or dehumidifying modes; then it may be because of insufficient air flow. Please check and make sure that you have appropriate size of ducting based on the capacity of your unit, all the vents & diffusers are fully open, the return grill size is appropriate, filters are clean and there is no obstruction to the air flow.

## 7 Water Level Protection

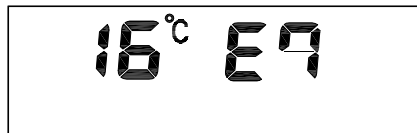

The control board is equipped with a function where an optional flow switch may be connected. In case a switch is used and water flow level is low, the system will shut down and display E7 error code. Make sure that the pump is working, the water lines as well as the strainer are clean and free from any obstruction. If you haven't connected a flow switch, and if the unit displays E7, please check and make sure the FS terminals on the circuit board are jumped.

## 8 Overheating protection

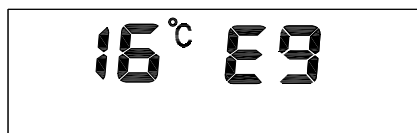

If your device displays E9, it means that the evaporator coil is getting too hot. MSWA units have a temperature sensor located on one of the evaporators copper tube. If the coils temperature gets above 145 °F ( 62 °C ), then, the compressor will be turned off to protect the unit. And, the unit will display E9. This may happen only on heating mode and once the air flow is insufficient. Please check and make sure that you have appropriate size of ducting based on the capacity of your unit, all the vents & diffusers are fully open, the return grill size is appropriate, filters are clean and there is no obstruction to the air flow. Improving the air flow will automatically resolve the issue.

## 9 Communication Error

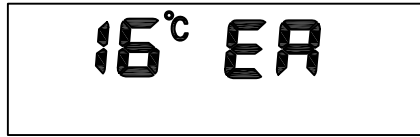

If your device displays EA, it means that the communication between wall control panel and the main circuit board is having some problems. This may be because the cable on the circuit board or on the wall control panel is loose or unplugged or the cable is broken. Please try to unplug the cable at both ends (RJ45 or RJ11 type jacks depending on serial number), and plug in again.

Please note that using an improper cable will not work and may damage the controller. The correct cable type depends on the model and serial number of your air conditioner. Please give us a call to verify the cable type.

# MALFUNCTIONS INSTRUCTION (MSWA Series)

## 10 No Power to the wall controller

If your control panel is not lighting up, then this may indicate a lack of power to your panel. Please make sure that you have power (110v or 220v depending on your model) between L and N terminals. If you have power and the panel still does not turn on, then check the fuse underneath a blue plastic cover on the circuit board, refer to the electrical panel diagram below. The fuse is 5X20 mm, 5 AMP. If the fuse blows again after replacement, check your pump and pump wirings. If you have checked the fuse and the control panel is still not lighting up, then check the transformer. There are four cables coming out (each two connected on both ends), plugged in to the circuit board. Unplug the two heads, and check for continuity between the two pins with a multimeter set to Ohms. If you do not have continuity, please call customer service to purchase a replacement transformer. If you have continuity, and you have already replaced the fuse and checked the transformer, then please call customer service.

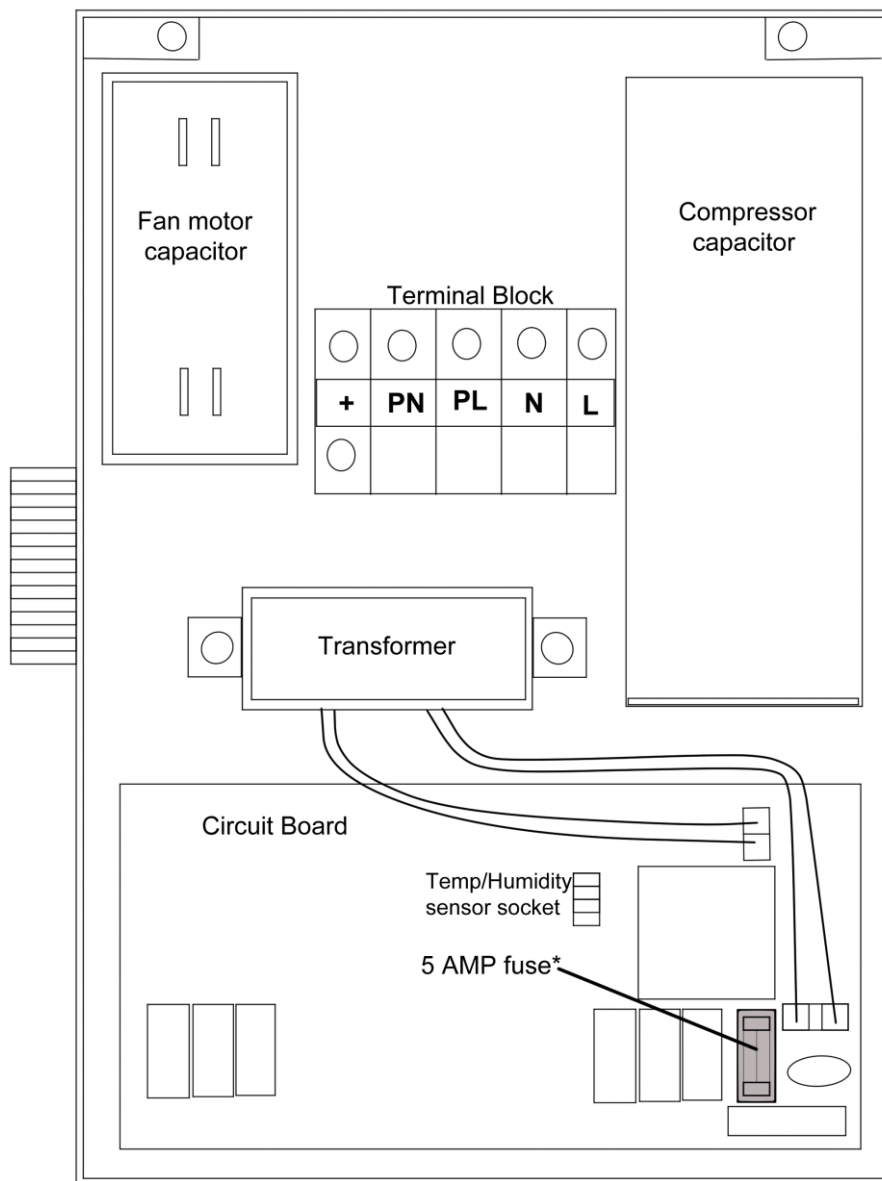

If you have any other questions, please visit the frequently asked questions section of our website at [www.marinaire.com](http://www.marinaire.com).

# MAINTENANCE

## Reversing Valves

Heat Pumps utilize a reversing valve; the valve must be energized periodically to keep the internal parts moving freely. To do this, switch the AC unit into heat for a few seconds, once a month.

## Seawater Strainer

Clean the strainer periodically. Check the discharge often for a steady stream of adequate water flow. Check seawater intake scoop for obstructions.

## Hoses & fittings

Make sure there is no leak at the connection points and also make sure that hoses are not looped, kinked, or crushed. The hoses connecting to the unit should be 5/8 inch ID braided marine grade hoses.

## Flushing the Condenser Coil

1. Turn off at the circuit breaker. Disconnect the inlet and outlet connections of the condenser coil.
2. Use chemical resistant pump and hoses to connect the inlet and outlet of the condenser coil
3. Use 20-25 gallon container to circulate the solution.
4. Flush the coil for about 30 minutes with a 5% solution of muriatic or hydrochloric acid and fresh water, or use a premixed over-the-counter solution.
5. Circulate fresh water through the coil to flush any residual acid from the system.

 **WARNING:** Dispose acid solutions in accordance with federal, state and/or local regulations.

## Return Air Filters

Check and clean the return air filter as necessary.

## Winterization

Once the ambient temperature ( air temperature) gets below 35° F , (2° C). The unit should not be operated at any mode (Cooling, heating, dehumidification or auto mode) . The air conditioning unit should be winterized immediately.

To avoid freezing during the winter, winterization is necessary. Do not leave sea water, fresh water, or air in the system . Fill antifreeze solution though the intake, strainer, pump and coil and water outlet (entire system).

 **Warning:** Collect all discharged liquids and recycle or dispose of in a proper manner.

# MANUFACTURERS LIMITED WARRANTY AGREEMENT

It is expressly understood that unless a statement is specifically identified as a warranty, statements made by MarinAire Technologies Inc. a Florida Limited Liability Company, ("MARINAIRE") or its representatives, relating to MARINAIRE's products, whether oral, written or contained in any sales literature, catalog or agreement, are not express warranties and do not form a part of the basis of the bargain, but are merely MARINAIRE's opinion or commendation of MARINAIRE's products.

**EXCEPT AS SPECIFICALLY SET FORTH HEREIN, THERE IS NO EXPRESS WARRANTY AS TO ANY OF MARINAIRE'S PRODUCTS. MARINAIRE MAKES NO WARRANTY AGAINST LATENT DEFECTS. MARINAIRE MAKES NO WARRANTY OF MERCHANTABILITY OF THE GOODS OR OF THE FITNESS OF THE GOODS FOR ANY PARTICULAR PURPOSE.**

## **GRANT OF LIMITED WARRANTY**

MARINAIRE warrants its products, purchased and retained in the United States of America to be free from defects in material and workmanship under normal use and maintenance as follows: Air conditioning, heating and/or heat pump units built by MARINAIRE ("MARINAIRE labelled Units") for One (1) year from the date of sale (as defined below); (2) Thermostats and control systems made by MARINAIRE, when installed with MARINAIRE Units, for one (1) year from the Date of sale (as defined below); (3) Sealed refrigerant circuit components of MARINAIRE Units (which components only include the compressor, refrigerant to air/water heat exchangers, reversing valve body and refrigerant metering device) for one (1) years from the date of sale (as defined below); Date of Sale Is the date of invoice created.

To make a claim under this warranty, Warranty Claim Form must be filed to MARINAIRE, and parts must be returned to MARINAIRE in Miami, FL, freight prepaid, no later than thirty (30) days after the date of the failure of the part; if MARINAIRE determines the part to be defective and within MARINAIRE's Limited Warranty, MARINAIRE shall, when such part has been either replaced or repaired, return such to a factory recognized distributor, dealer or service organization, F.O.B. MARINAIRE, Miami, FL., freight collect. The warranty on any part repaired or replaced under warranty expires at the end of the original warranty period.

This warranty does not cover and does not apply to: (1) Air filters, grilles, fittings, hoses, air ducts, circulation pumps, refrigerant, fluids, oil; (2) Products relocated after initial installation; (3) Any portion or component of any system that is not supplied by MARINAIRE, regardless of the cause of the failure of such portion or component; (4) Products on which the unit identification tags or labels have been removed or defaced; (5) Products on which payment to MARINAIRE, or to the owner's seller, is in default; (6) Products subjected to improper or inadequate installation, maintenance, repair, wiring or voltage conditions; (7) Products subjected to accident, misuse, negligence, abuse, fire, flood, lightning, unauthorized alteration, misapplication, contaminated or corrosive air or liquid supply, operation at out of range air or water temperatures or flow rates, or opening of the refrigerant circuit by unqualified personnel; (8) Mold, fungus, sand, mud, seaweed or bacteria damages; (9) Corrosion or Abrasion of the product; (10) Products, parts and components supplied by others; (11) Products which have been operated in a manner contrary to MARINAIRE's printed instructions; (12) Products which have insufficient performance as a result of improper duct or plumbing system design or improper application, installation, or use of MARINAIRE's products; or (13) Electricity or fuel costs, or any increases or unrealized savings in same, for any reason whatsoever.

MARINAIRE is not responsible for: (1) The costs of any system components supplied by others, oil, refrigerant or, associated labor to repair or replace the same, which is incurred as a result of a defective part covered by MARINAIRE's Limited Warranty; (2) The costs of labor, refrigerant, materials or service incurred in diagnosis and removal of the defective part, or in obtaining and replacing the new or repaired part; (3) Transportation costs (4) The costs of normal maintenance.



# MANUFACTURERS LIMITED WARRANTY AGREEMENT

## **LIMITATION OF REMEDIES**

In the event of a breach of the Limited Warranty, MARINAIRE will only be obligated at MARINAIRE's option to repair the failed part or unit, or to furnish a new or rebuilt part or unit in exchange for the part or unit which has failed. If after written notice to MARINAIRE in Miami, FL. of each defect, malfunction or other failure, and a reasonable number of attempts by MARINAIRE to correct the defect, malfunction or other failure, and the remedy fails of its essential purpose, MARINAIRE shall refund the purchase price paid to MARINAIRE in exchange for the return of the sold good(s). Said refund shall be the maximum liability of MARINAIRE.

**THIS REMEDY IS THE SOLE ANDEXCLUSIVE REMEDY OF THE BUYER OR PURCHASER AGAINST MARINAIRE FOR BREACH OF CONTRACT, FOR THE BREACH OF ANY WARRANTY OR FOR MARINAIRE'S NEGLIGENCE OR IN STRICT LIABILITY.**

## **LIMITATION OF LIABILITY**

MARINAIRE shall have no liability for any damages if MARINAIRE's performance is delayed for any reason or is prevented to any extent by any event such as, but not limited to: any war, civil unrest, government restrictions or restraints, strikes, or work stoppages, fire, flood, accident, shortages of transportation, fuel, material, or labor, acts of God or any other reason beyond the sole control of MARINAIRE.

**MARINAIRE EXPRESSLY DISCLAIMS AND EXCLUDES ANY LIABILITY FOR CONSEQUENTIAL OR INCIDENTAL DAMAGE IN CONTRACT, FOR BREACH OF ANY IMPLIED WARRANTY, OR IN TORT, WHETHER FOR MARINAIRE'S NEGLIGENCE OR AS STRICT LIABILITY.**

## **OBTAINING WARRANTY PERFORMANCE**

Normally, the dealer or service organization who installed the products will provide warranty performance for the owner. Should the installer be unavailable, contact any MARINAIRE recognized distributor, dealer or service organization. If assistance is required in obtaining warranty performance, write or call:

MarinAire Technologies Inc  
11129 NW 122nd St  
Medley FL 33178

Toll Free: 1-800-724-8071  
Fax: 1-305-748-6071  
service@marinaire.com

NCSMS00019A00-D